

Riser Swing Check Valve | Grooved Ends

Technical Features

- **Connections:** Grooved Ends (AWWA C606)
- **Sizes:** 2", 2-1/2", 3", 4", 6", 8"
- **Approvals:** UL, ULC, and FM
- **Maximum Working Pressure:** 300PSI (Max. Test Pressure: 600PSI)
- **Maximum Working Temperature:** 250°F (120°C)
- **Application:** Indoor and Outdoor Use
- Low pressure-drop, non-slam performance



Component	Material	Specification
1	Body	Ductile Iron ASTM A536 Nylon-11 Coated
2	Clapper	Stainless Steel ANSI 304
3	Coil Spring	Stainless Steel ANSI 302
4	Nut	Stainless Steel ANSI 304
5	Bolt	Stainless Steel ANSI 304
6	Washer	Stainless Steel ANSI 304
7	Facing Seal	Rubber EPDM
8	Seat Ring	Stainless Steel ANSI 304
9	Drain Plug	Ductile Iron ASTM A536
10	Pin Plug	Ductile Iron ASTM A536
11	Bushing	Aluminum Bronze B148
12	Hinge Pin	Stainless Steel ANSI 304
13	Hook	Steel ASTM A307

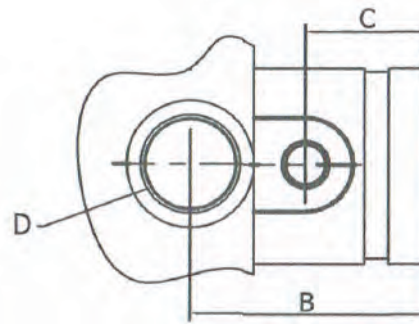
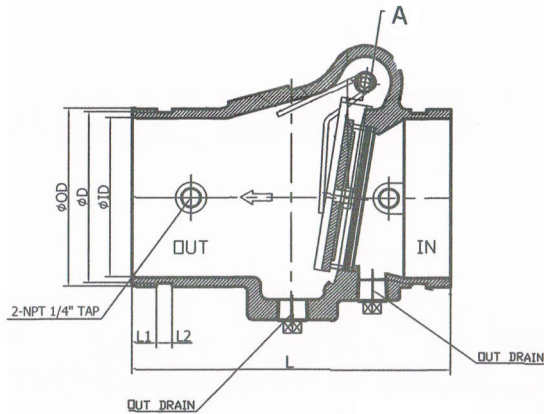

Dimensions:

Size	D1		D2		D3		L		L1		L2		A		B		C		D		Weight lbs
	in	mm	in	mm	in	mm	in	mm	in	mm	in	mm	in	mm	in	mm	in	mm	in	mm	
2"	1.9	49.0	2.2	57.1	2.4	60.3	6.7	170.0	0.6	15.8	0.3	8.7	0.4	9.5	3.7	95.0	1.7	43.0	1.0	25.4	8.0
2-1/2"	2.4	62.2	2.7	69.0	2.9	73.0	7.2	184.0	0.6	15.8	0.3	8.7	0.4	9.5	3.7	93.0	1.6	41.0	1.3	31.8	8.5
3"	2.9	74.0	3.3	84.7	3.5	89.1	7.7	195.0	0.6	15.8	0.3	8.7	0.4	9.5	3.8	97.0	1.7	42.0	1.3	31.8	10.5
4"	3.9	98.0	4.3	109.8	4.5	114.3	8.1	205.0	0.6	15.8	0.3	8.7	0.5	12.7	4.4	113.0	2.0	50.0	2.0	50.8	17.0
6"	6.1	156.0	6.4	163.7	6.6	168.3	12.6	320.0	0.6	15.8	0.3	8.7	0.5	12.7	5.7	146.0	2.4	60.0	2.0	50.8	42.5
8"	7.9	201.6	8.5	215.8	8.6	218.2	14.6	372.0	0.8	20.1	0.4	10.5	0.5	12.7	6.9	176.0	2.8	70.0	2.0	50.8	66.5