

PIV NRS Gate Valve | Flanged

Technical Features

- **Connections:** Flanged Ends (ANSI B16.1 Class 125)
- **Sizes:** 2-1/2", 3", 4", 5", 6", 8", 10", 12"
- **Approvals:** UL, ULC, FM, NSF, ANSI 61 & 372
- **Maximum Working Pressure:** 300PSI (Max. Test Pressure: 600PSI)
- **Maximum Working Temperature:** 180°F (82°C)
- Complies with AWWA C515
- NPT Plug on Body
- Fusion Bonded Epoxy Coated Interior and Exterior to AWWA C550



Component	Material	Specification
Body	Ductile Iron	A536 65-45-12
Wedge	Ductile Iron, EPDM Encapsulated	
Wedge Nut	Bronze	B62 C83600
Stem	Stainless Steel	AISI 420
Bonnet	Ductile Iron	A536 65-45-12
Gasket	Rubber	EPDM
Gland	Ductile Iron	A536 65-45-12
Thrust Collar	Bronze	B62 C83600
O-Ring	Rubber	EPDM
Post Flange	Ductile Iron	A536 65-45-12
Operating Nut	Ductile Iron	A536 65-45-12
NPT Plug	Malleable Iron	Commercial
Post Flange Bolt	Stainless Steel	AISI 316
Bonnet Bolt	Stainless Steel	AISI 304

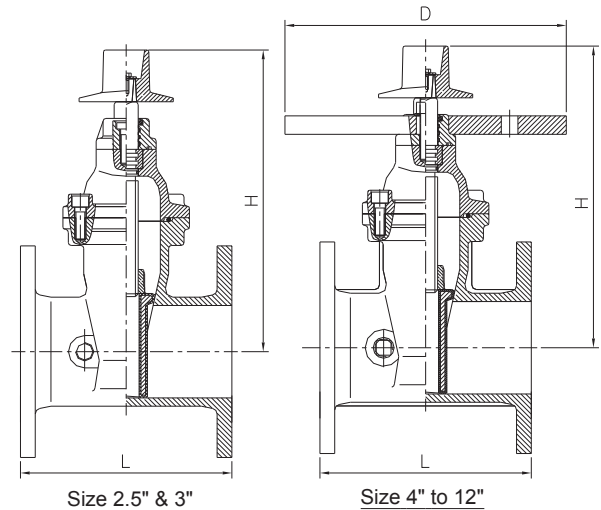

Dimensions:

Size	L		H		D		Weight lbs
	in	mm	in	mm	in	mm	
2-1/2"	7.5	190.5	10.6	270.0			31.0
3"	8.0	203.0	11.7	296.0			41.0
4"	9.0	229.0	13.8	350.0	12.0	305.0	64.0
5"	10.0	254.0	16.1	410.0	12.0	305.0	79.0
6"	10.5	267.0	17.9	455.0	12.0	305.0	103.0
8"	11.5	292.0	21.5	545.0	12.0	305.0	161.0
10"	13.0	330.0	25.4	645.0	12.0	305.0	235.0
12"	14.0	356.0	28.7	730.0	12.0	305.0	339.0